

Polines Serie CEMA C Dimensiones y Códigos

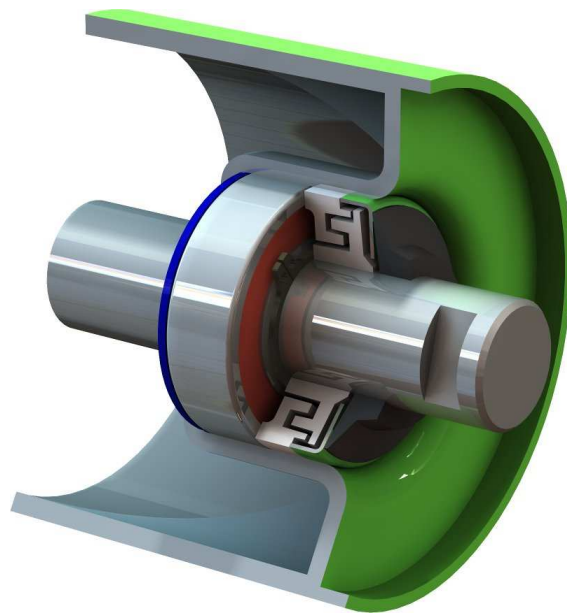

Clave para la codificación de estaciones de polines

El código que identifica a la estación se forma de acuerdo a los valores de seis variables:



Tabla A

v3	Tipo de estación
00	Carga
01	Carga plana
02	Carga garland
20	Impacto
21	Impacto plana
22	Impacto garland
40	Retorno plana
41	Retorno con discos
42	Retorno helicoidal
43	Retorno garland
44	Retorno garland con discos
45	Retorno en V
46	Retorno en V con discos
47	Retorno en V invertida
48	Retorno en V invertida con discos
60	Centradora de carga
61	Centradora de carga con patines
62	Centradora de retorno plana
63	Centradora de retorno plana con patines
64	Centradora de retorno con discos
65	Centradora de retorno con discos y patines
66	Centradora de retorno helicoidal
67	Centradora de retorno helicoidal con patines
68	Centradora de retorno en V con patines
69	Centradora de retorno en V con discos y patines
80	Alimentadora de carga
81	Alimentadora de impacto
82	Ángulo variable
83	Live shaft
84	Pesométrica
85	Wire rope

Tabla B

v4	Ángulo
0	0°
1	10°
2	20°
3	35°
4	45°
5	55°
6	5°
7	15°
8	27°

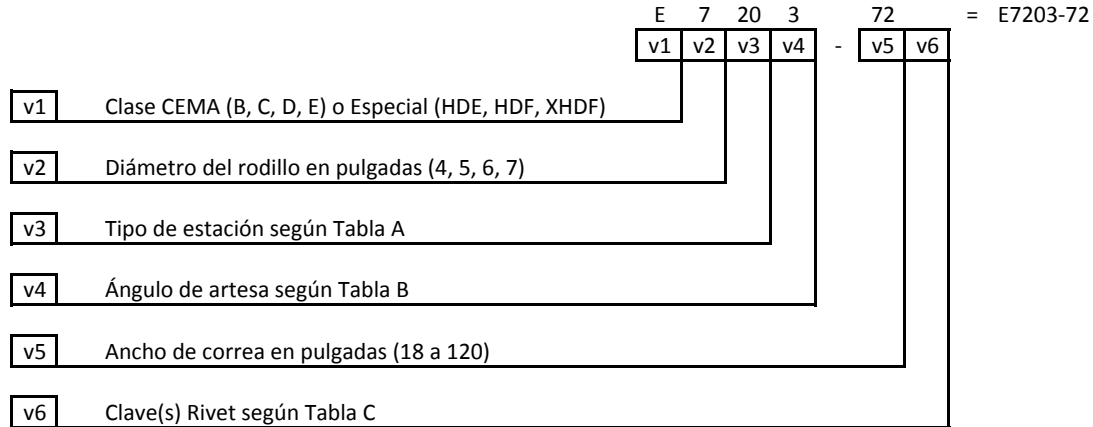
Tabla C

v6	Descripción
S	Lubricado y sellado de por vida
R	Lubricado y reengrasable
W	Estación de base ancha.
D	Soporte Lateral Desmontable
H	Soporte alto

Ejemplos

i. Estación de carga garland, clase CEMA E, con rodillos de 7" de diámetro, sellados, ángulo de artesa 35°, para correa de 60" de ancho:

$$\begin{array}{|c|c|c|c|} \hline v1 & v2 & v3 & v4 \\ \hline E & 7 & 02 & 3 \\ \hline \end{array} - \begin{array}{|c|c|} \hline v5 & v6 \\ \hline 60 & S \\ \hline \end{array} = E7023-60S$$

ii. Estación de impacto con soporte lateral desmontable, clase HDF, rodillos de 7" de diámetro, sellados, ángulo de artesa 35°, para correa de 54" de ancho:

$$\begin{array}{|c|c|c|c|} \hline v1 & v2 & v3 & v4 \\ \hline HDF & 7 & 20 & 3 \\ \hline \end{array} - \begin{array}{|c|c|} \hline v5 & v6 \\ \hline 54 & SD \\ \hline \end{array} = HDF7203-54SD$$

Estación de Carga

Serie CEMA C
 Servicio Mediano

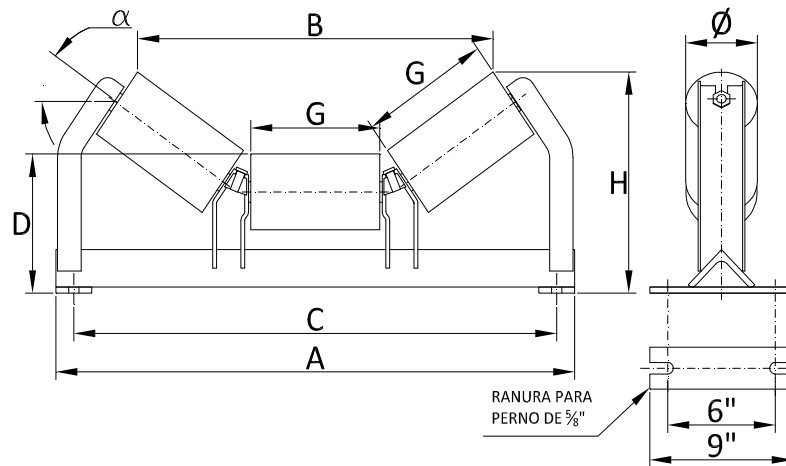

Ancho Correa ["]	Código		Ángulo Artesa [°]	A ["]	B ["]		C ["]	D ["]		G ["]	H ["]	
	Ø Rodillo ["]				Ø Rodillo ["]			Ø Rodillo ["]			Ø Rodillo ["]	
	5	6			5	6		5	6		5	6
18	C5002-18	C6002-18	20	29 1/2	21 1/2	21 1/8	27	8 1/2	9	6 7/8	11	11 1/2
	C5003-18	C6003-18	35		19 1/4	18 11/16					12 11/16	13 1/8
	C5004-18	C6004-18	45		17 13/16	17 1/16					13 5/8	13 15/16
20	C5002-20	C6002-20	20	31 1/2	23 5/16	23	29	8 1/2	9	7 9/16	11 1/4	11 3/4
	C5003-20	C6003-20	35		21	20 7/16					13 1/8	13 1/2
	C5004-20	C6004-20	45		19 7/16	18 3/4					14 1/16	14 7/16
24	C5002-24	C6002-24	20	35 1/2	27 1/4	26 7/8	33	8 1/2	9	8 7/8	11 11/16	12 3/16
	C5003-24	C6003-24	35		24 1/2	23 15/16					13 13/16	14 1/4
	C5004-24	C6004-24	45		22 5/8	21 15/16					15 1/16	15 3/8
30	C5002-30	C6002-30	20	41 1/2	33	32 5/8	39	8 1/2	9	10 7/8	12 3/8	12 7/8
	C5003-30	C6003-30	35		29 13/16	29 1/4					14	15 3/8
	C5004-30	C6004-30	45		27 1/2	26 3/4					16 7/16	16 13/16
36	C5002-36	C6002-36	20	47 1/2	38 3/4	38 3/8	45	8 1/2	9	12 7/8	13 1/16	13 9/16
	C5003-36	C6003-36	35		35 1/16	34 1/2					16 1/8	16 1/2
	C5004-36	C6004-36	45		32 5/16	31 5/8					17 7/8	18 1/4
42	C5002-42	C6002-42	20	53 1/2	44 1/2	44 1/8	51	9	9 1/2	14 7/8	14 1/4	14 3/4
	C5003-42	C6003-42	35		40 3/8	39 13/16					17 3/4	18 3/16
	C5004-42	C6004-42	45		37 3/16	36 13/16					19 13/16	20 1/8
48	C5002-48	C6002-48	20	59 1/2	50 1/4	49 7/8	57	9	9 1/2	16 7/8	14 15/16	15 7/16
	C5003-48	C6003-48	35		45 5/8	45 1/16					18 7/8	19 5/16
	C5004-48	C6004-48	45		42	41 5/16					21 1/4	21 9/16
54	C5002-54	C6002-54	20	65 1/2	56	55 5/8	63	9 1/4	9 3/4	18 7/8	15 7/8	16 3/8
	C5003-54	C6003-54	35		50 15/16	50 3/8					20 5/16	20 11/16
	C5004-54	C6004-54	45		46 7/8	46 1/8					22 7/8	23 1/4
60	C5002-60	C6002-60	20	71 1/2	61 3/4	61 3/8	69	9 1/4	9 3/4	20 7/8	16 9/16	17 1/16
	C5003-60	C6003-60	35		56 3/16	55 5/8					21 7/16	21 13/16
	C5004-60	C6004-60	45		51 11/16	50					24 5/16	24 11/16

Estaciones de base ancha: sumar 6" a cotas A y C. Agregar W a código según nomenclatura
 Medidas pueden ser modificadas para adaptarse a requerimientos del Cliente
 Diseño sujeto a cambio sin previo aviso.

Estación de Carga Plana

Serie CEMA C
 Servicio Mediano

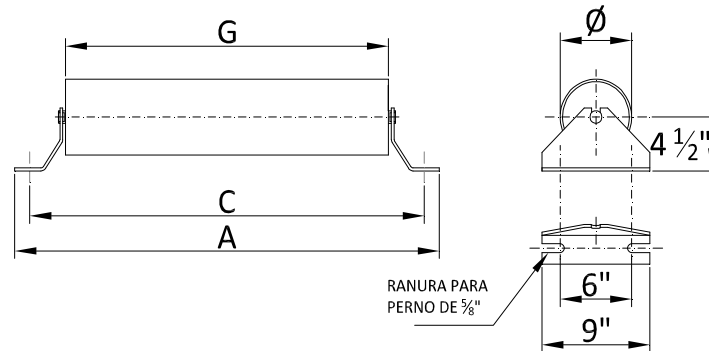

Ancho Correa ["]	Código		A ["]	C ["]	G ["]
	Ø Rodillo ["]				
	5	6			
18	C5010-18	C6010-18	29	27	21
20	C5010-20	C6010-20	31	29	23
24	C5010-24	C6010-24	35	33	27
30	C5010-30	C6010-30	41	39	33
36	C5010-36	C6010-36	47	45	39
42	C5010-42	C6010-42	53	51	45
48	C5010-48	C6010-48	59	57	51
54	C5010-54	C6010-54	65	63	57
60	C5010-60	C6010-60	71	69	63

Estaciones de base ancha: sumar 6" a cotas A y C. Agregar W a código según nomenclatura
 Medidas pueden ser modificadas para adaptarse a requerimientos del Cliente
 Diseño sujeto a cambio sin previo aviso.

Estación de Carga Garland

Serie CEMA C
 Servicio Mediano

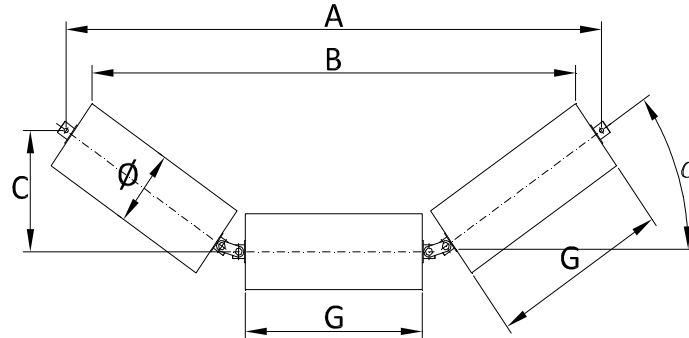

Ancho Correa ["]	Código		Ángulo Artesa [°]	A ["]		B ["]		C ["]	G ["]
	Ø Rodillo ["]			Ø Rodillo ["]		Ø Rodillo ["]			
	5	6		5	6	5	6		
24	C5022-24	C6022-24	20	33 3/8		30 11/16	30 5/16	4 1/16	9 7/8
	C5023-24	C6023-24	35	30 15/16		27 1/8	26 9/16	7	
	C5024-24	C6024-24	45	29 1/2		24 7/8	24 3/16	9 1/16	
30	C5022-30	C6022-30	20	36 3/4		34	33 3/4	4 1/2	11 1/16
	C5023-30	C6023-30	35	34 7/16		30 9/16	29 15/16	7 3/4	
	C5024-30	C6024-30	45	32 3/8		27 3/4	27 1/16	9 15/16	
36	C5022-36	C6022-36	20	42 7/16		39 3/4	39 3/8	5 3/16	13
	C5023-36	C6023-36	35	39 11/16		35 3/4	35 3/16	8 7/8	
	C5024-36	C6024-36	45	37 1/16		32 1/2	31 3/4	11 3/8	
42	C5022-42	C6022-42	20	48 3/16		45 3/8	45 1/16	5 13/16	14 15/16
	C5023-42	C6023-42	35	44 7/8		40 15/16	40 3/8	10	
	C5024-42	C6024-42	45	41 7/8		37 1/4	36 1/2	12 11/16	
48	C5022-48	C6022-48	20	56 3/4		54	53 5/8	6 1/2	17 7/8
	C5023-48	C6023-48	35	52 3/4		48 13/16	48 1/4	11 3/4	
	C5024-48	C6024-48	45	49 7/16		44 13/16	44 3/16	14 15/16	

Estaciones de base ancha: sumar 6" a cotas A y C. Agregar W a código según nomenclatura
 Medidas pueden ser modificadas para adaptarse a requerimientos del Cliente
 Diseño sujeto a cambio sin previo aviso.

Estación de Impacto

Serie CEMA C
 Servicio Mediano

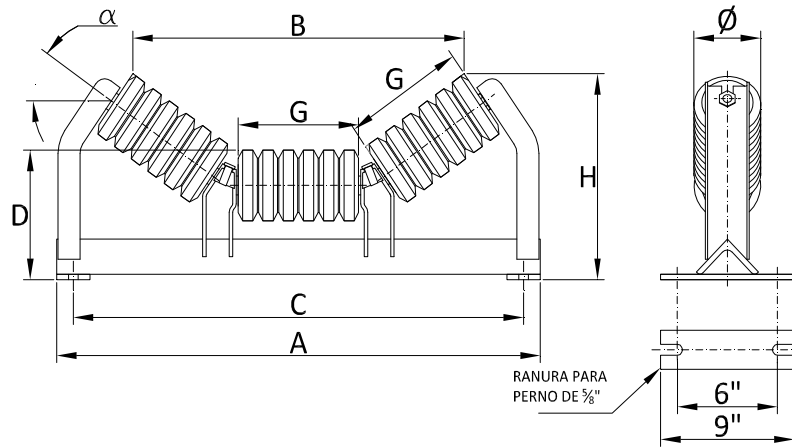

Ancho Correa [""]	Código		Ángulo Artesa [°]	A [""]	B [""]		C [""]	D [""]		G [""]	H [""]	
	Ø Rodillo [""]				Ø Rodillo [""]			Ø Rodillo [""]			Ø Rodillo [""]	
	5	6			5	6		5	6		5	6
18	C5202-18	C6202-18	20	29 1/2	21 1/2	21 1/8	27	8 1/2	9	6 7/8	11	11 1/2
	C5203-18	C6203-18	35		19 1/4	18 11/16					12 11/16	13 1/8
	C5204-18	C6204-18	45		17 13/16	17 1/16					13 5/8	13 15/16
20	C5202-20	C6202-20	20	31 1/2	23 5/16	23	29	8 1/2	9	7 9/16	11 1/4	11 3/4
	C5203-20	C6203-20	35		21	20 7/16					13 1/8	13 1/2
	C5204-20	C6204-20	45		19 7/16	18 3/4					14 1/16	14 7/16
24	C5202-24	C6202-24	20	35 1/2	27 1/4	26 7/8	33	8 1/2	9	8 7/8	11 11/16	12 3/16
	C5203-24	C6203-24	35		24 1/2	23 15/16					13 13/16	14 1/4
	C5204-24	C6204-24	45		22 5/8	21 15/16					15 1/16	15 3/8
30	C5202-30	C6202-30	20	41 1/2	33	32 5/8	39	8 1/2	9	10 7/8	12 3/8	12 7/8
	C5203-30	C6203-30	35		29 13/16	29 1/4					14	15 3/8
	C5204-30	C6204-30	45		27 1/2	26 3/4					16 7/16	16 13/16
36	C5202-36	C6202-36	20	47 1/2	38 3/4	38 3/8	45	8 1/2	9	12 7/8	13 1/16	13 9/16
	C5203-36	C6203-36	35		35 1/16	34 1/2					16 1/8	16 1/2
	C5204-36	C6204-36	45		32 5/16	31 5/8					17 7/8	18 1/4
42	C5202-42	C6202-42	20	53 1/2	44 1/2	44 1/8	51	9	9 1/2	14 7/8	14 1/4	14 3/4
	C5203-42	C6203-42	35		40 3/8	39 13/16					17 3/4	18 3/16
	C5204-42	C6204-42	45		37 3/16	36 13/16					19 13/16	20 1/8
48	C5202-48	C6202-48	20	59 1/2	50 1/4	49 7/8	57	9	9 1/2	16 7/8	14 15/16	15 7/16
	C5203-48	C6203-48	35		45 5/8	45 1/16					18 7/8	19 5/16
	C5204-48	C6204-48	45		42	41 5/16					21 1/4	21 9/16
54	C5202-54	C6202-54	20	65 1/2	56	55 5/8	63	9 1/4	9 3/4	18 7/8	15 7/8	16 3/8
	C5203-54	C6203-54	35		50 15/16	50 3/8					20 5/16	20 11/16
	C5204-54	C6204-54	45		46 7/8	46 1/8					22 7/8	23 1/4
60	C5202-60	C6202-60	20	71 1/2	61 3/4	61 3/8	69	9 1/4	9 3/4	20 7/8	16 9/16	17 1/16
	C5203-60	C6203-60	35		56 3/16	55 5/8					21 7/16	21 13/16
	C5204-60	C6204-60	45		51 11/16	50					24 5/16	24 11/16

Estaciones de base ancha: sumar 6" a cotas A y C. Agregar W a código según nomenclatura
 Medidas pueden ser modificadas para adaptarse a requerimientos del Cliente
 Diseño sujeto a cambio sin previo aviso.

Estación de Impacto Plana

Serie CEMA C
 Servicio Mediano

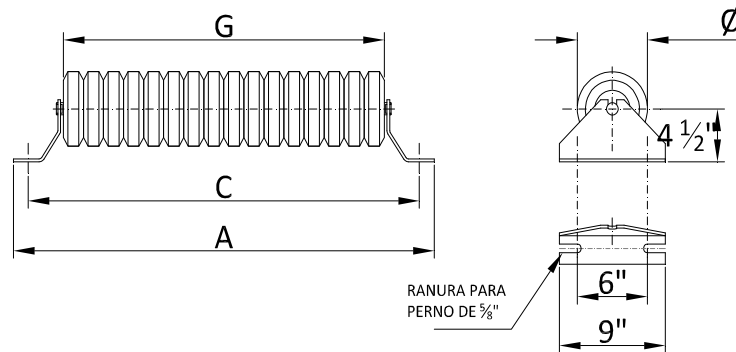

Ancho Correa ["]	Código		A ["]	C ["]	G ["]
	Ø Rodillo ["]				
	5	6			
18	C5210-18	C6210-18	29	27	21
20	C5210-20	C6210-20	31	29	23
24	C5210-24	C6210-24	35	33	27
30	C5210-30	C6210-30	41	39	33
36	C5210-36	C6210-36	47	45	39
42	C5210-42	C6210-42	53	51	45
48	C5210-48	C6210-48	59	57	51
54	C5210-54	C6210-54	65	63	57
60	C5210-60	C6210-60	71	69	63

Estaciones de base ancha: sumar 6" a cotas A y C. Agregar W a código según nomenclatura
 Medidas pueden ser modificadas para adaptarse a requerimientos del Cliente
 Diseño sujeto a cambio sin previo aviso.

Estación de Retorno Plana

Serie CEMA C
 Servicio Mediano

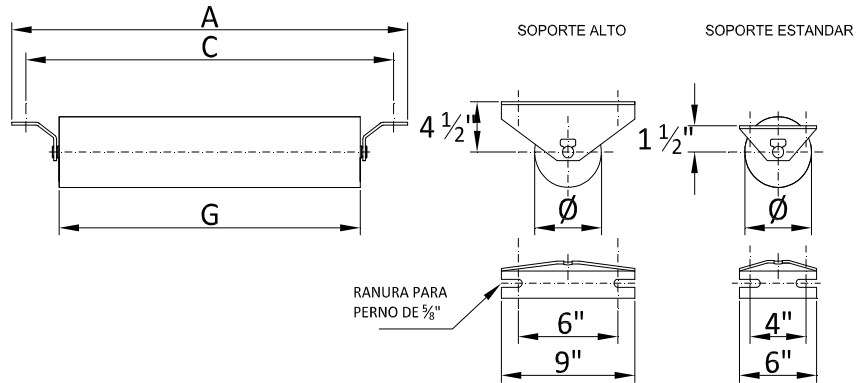

Ancho Correa ["]	Código		A ["]	C ["]	G ["]
	Ø Rodillo ["]				
	5	6			
18	C5400-18	C6400-18	29	27	21
20	C5400-20	C6400-20	31	29	23
24	C5400-24	C6400-24	35	33	27
30	C5400-30	C6400-30	41	39	33
36	C5400-36	C6400-36	47	45	39
42	C5400-42	C6400-42	53	51	45
48	C5400-48	C6400-48	59	57	51
54	C5400-54	C6400-54	65	63	57
60	C5400-60	C6400-60	71	69	63

Estaciones de base ancha: sumar 6" a cotas A y C. Agregar W a código según nomenclatura
 Medidas pueden ser modificadas para adaptarse a requerimientos del Cliente
 Diseño sujeto a cambio sin previo aviso.

Estación de Retorno con Discos de Goma

Serie CEMA C
 Servicio Mediano

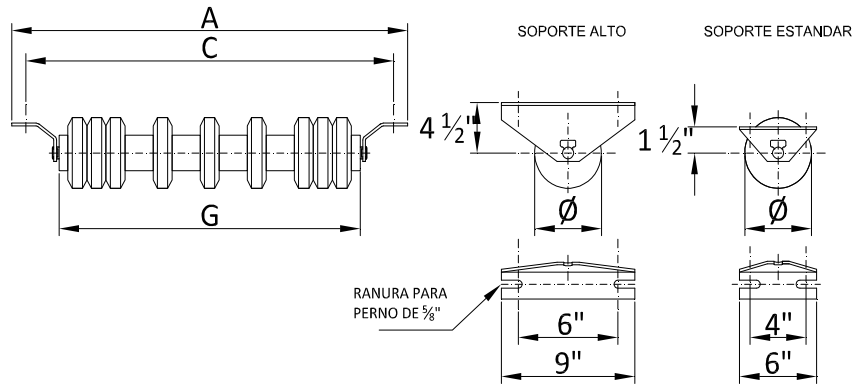

Ancho Correa ["]	Código		A ["]	C ["]	G ["]
	Ø Rodillo ["]				
	5	6			
18	C5410-18	C6410-18	29	27	21
20	C5410-20	C6410-20	31	29	23
24	C5410-24	C6410-24	35	33	27
30	C5410-30	C6410-30	41	39	33
36	C5410-36	C6410-36	47	45	39
42	C5410-42	C6410-42	53	51	45
48	C5410-48	C6410-48	59	57	51
54	C5410-54	C6410-54	65	63	57
60	C5410-60	C6410-60	71	69	63

Estaciones de base ancha: sumar 6" a cotas A y C. Agregar W a código según nomenclatura
 Medidas pueden ser modificadas para adaptarse a requerimientos del Cliente
 Diseño sujeto a cambio sin previo aviso.

Estación de Retorno Helicoidal

Serie CEMA C
 Servicio Mediano

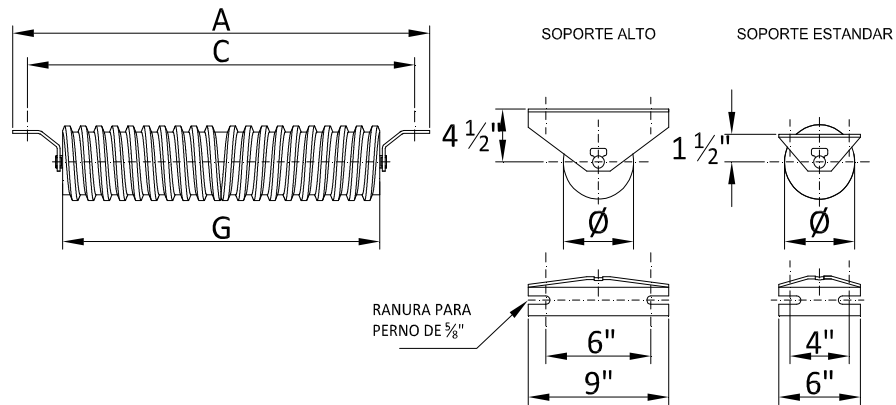

Ancho Correa ["]	Código		A ["]	C ["]	G ["]
	Ø Rodillo ["]				
	5	6			
18	C5420-18	C6420-18	29	27	21
20	C5420-20	C6420-20	31	29	23
24	C5420-24	C6420-24	35	33	27
30	C5420-30	C6420-30	41	39	33
36	C5420-36	C6420-36	47	45	39
42	C5420-42	C6420-42	53	51	45
48	C5420-48	C6420-48	59	57	51
54	C5420-54	C6420-54	65	63	57
60	C5420-60	C6420-60	71	69	63

Estaciones de base ancha: sumar 6" a cotas A y C. Agregar W a código según nomenclatura
 Medidas pueden ser modificadas para adaptarse a requerimientos del Cliente
 Diseño sujeto a cambio sin previo aviso.

Estación de Retorno Garland

Serie CEMA C
 Servicio Mediano

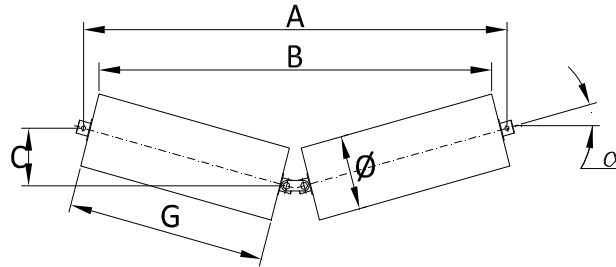

Ancho Correa ["]	Código		Ángulo Artesa [°]	A ["]	B ["]		C ["]	G ["]
	Ø Rodillo ["]				Ø Rodillo ["]			
	5	6			5	6		
24	C5431-24	C6431-24	10	30 7/8	28 13/16	28 9/16	2 5/8	13 3/4
	C5437-24	C6437-24	15		28 1/4	28		
30	C5431-30	C6431-30	10	36 11/16	34 9/16	34 7/16	3 1/8	16 3/4
	C5437-30	C6437-30	15		33 15/16	33 3/4		
36	C5431-36	C6431-36	10	42 1/2	40 3/8	40 1/4	3 11/16	19 11/16
	C5437-36	C6437-36	15		39 11/16	39 7/16		
42	C5431-42	C6431-42	10	48 5/16	46 1/4	46 1/16	4 3/16	22 5/8
	C5437-42	C6437-42	15		45 3/8	45 1/8		
48	C5431-48	C6431-48	10	53 15/16	52 1/16	51 7/8	4 11/16	25 9/16
	C5437-48	C6437-48	15		51 1/16	50 13/16		

Estaciones de base ancha: sumar 6" a cotas A y C. Agregar W a código según nomenclatura
 Medidas pueden ser modificadas para adaptarse a requerimientos del Cliente
 Diseño sujeto a cambio sin previo aviso.

Estación de Retorno Garland con Discos de Goma

Serie CEMA C
 Servicio Mediano

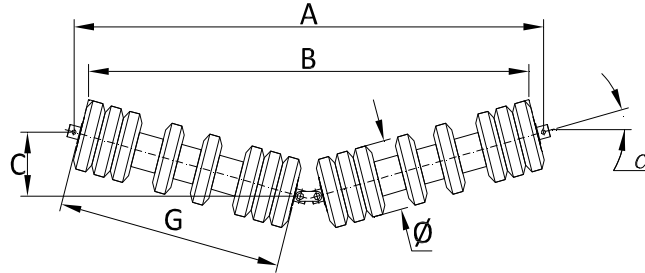

Ancho Correa ["]	Código		Ángulo Artesa [°]	A ["]	B ["]		C ["]	G ["]
	Ø Rodillo ["]				Ø Rodillo ["]			
	5	6			5	6		
24	C5446-24	C6446-24	5	30 11/16	29 1/8	29 1/16	1 5/16	13 3/4
	C5441-24	C6441-24	10	30 7/8	28 13/16	28 9/16	2 5/8	
	C5447-24	C6447-24	15	31	28 1/4	28	3 15/16	
30	C5446-30	C6446-30	5	36 9/16	34 15/16	34 15/16	1 9/16	16 3/4
	C5441-30	C6441-30	10	36 11/16	34 9/16	34 7/16	3 1/8	
	C5447-30	C6447-30	15	36 3/4	33 15/16	33 3/4	4 3/4	
36	C5446-36	C6446-36	5	42 7/16	40 7/8	40 13/16	1 13/16	19 11/16
	C5441-36	C6441-36	10	42 1/2	40 3/8	40 1/4	3 11/16	
	C5447-36	C6447-36	15	42 7/16	39 11/16	39 7/16	5 7/16	
42	C5446-42	C6446-42	5	48 1/4	46 3/4	46 11/16	2 1/16	22 5/8
	C5441-42	C6441-42	10	48 5/16	46 1/4	46 1/16	4 3/16	
	C5447-42	C6447-42	15	48 1/8	45 3/8	45 1/8	6 1/4	
48	C5446-48	C6446-48	5	54 3/16	52 5/8	52 9/16	2 3/8	25 9/16
	C5441-48	C6441-48	10	53 15/16	52 1/16	51 7/8	4 11/16	
	C5447-48	C6447-48	15	53 13/16	51 1/16	50 13/16	7 1/16	

Estaciones de base ancha: sumar 6" a cotas A y C. Agregar W a código según nomenclatura
 Medidas pueden ser modificadas para adaptarse a requerimientos del Cliente
 Diseño sujeto a cambio sin previo aviso.

Estación de Retorno en V

Serie CEMA C
 Servicio Mediano

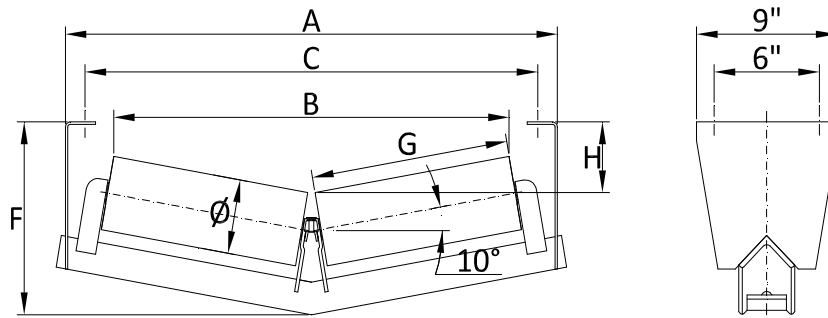

Base Estándar

Ancho Correa ["]	Código		B ["]		G ["]	A ["]	C ["]	F ["]	H ["]	
	Ø Rodillo ["]		Ø Rodillo ["]						Ø Rodillo ["]	
	5	6	5	6					5	6
36	C5451-36	C6451-36	39 7/16	39 1/4	19 17/27	47 3/4	45	15 13/16	7	6 1/2
42	C5451-42	C6451-42	45 3/8	45 3/16	22 17/27	53 3/4	51	16 5/16	7 1/2	7
48	C5451-48	C6451-48	51 1/4	51 1/16	25 17/27	59 3/4	57	16 13/16	8	7 1/2
54	C5451-54	C6451-54	57 1/8	56 15/16	28 17/27	65 3/4	63	17 5/16	8 1/2	8
60	C5451-60	C6451-60	63 1/16	62 7/8	31 17/27	71 3/4	69	17 13/16	9	8 1/2

Base Ancha

Ancho Correa ["]	Código		B ["]		G ["]	A ["]	C ["]	F ["]	H ["]	
	Ø Rodillo ["]		Ø Rodillo ["]						Ø Rodillo ["]	
	5	6	5	6					5	6
36	C5451-36W	C6451-36W	39 7/16	39 1/4	19 17/27	53 3/4	51	16 5/16	7 1/2	7
42	C5451-42W	C6451-42W	45 3/8	45 3/16	22 17/27	59 3/4	57	16 13/16	8	7 1/2
48	C5451-48W	C6451-48W	51 1/4	51 1/16	25 17/27	65 3/4	63	17 5/16	8 1/2	8
54	C5451-54W	C6451-54W	57 1/8	56 15/16	28 17/27	71 3/4	69	17 13/16	9	8 1/2
60	C5451-60W	C6451-60W	63 1/16	62 7/8	31 17/27	77 3/4	75	18 5/16	9 1/2	9

Estación de Retorno en V con Discos de Goma

Serie CEMA C
 Servicio Mediano

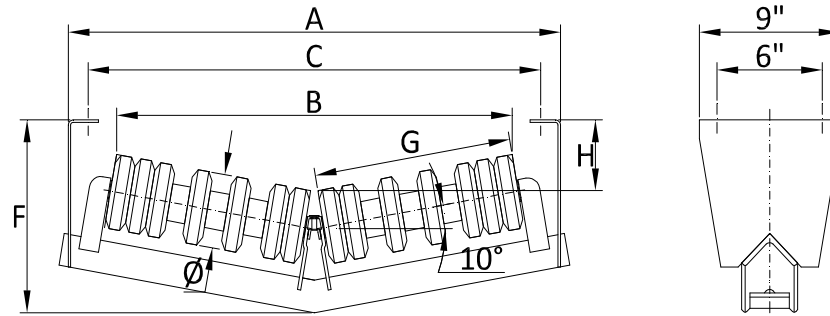

Base Estándar

Ancho Correa ["]	Código		B ["]		G ["]	A ["]	C ["]	F ["]	H ["]	
	Ø Rodillo ["]		Ø Rodillo ["]						Ø Rodillo ["]	
	5	6	5	6					5	6
36	C5461-36	C6461-36	39 7/16	39 1/4	19 17/27	47 3/4	45	15 13/16	7	6 1/2
42	C5461-42	C6461-42	45 3/8	45 3/16	22 17/27	53 3/4	51	16 5/16	7 1/2	7
48	C5461-48	C6461-48	51 1/4	51 1/16	25 17/27	59 3/4	57	16 13/16	8	7 1/2
54	C5461-54	C6461-54	57 1/8	56 15/16	28 17/27	65 3/4	63	17 5/16	8 1/2	8
60	C5461-60	C6461-60	63 1/16	62 7/8	31 17/27	71 3/4	69	17 13/16	9	8 1/2

Base Ancha

Ancho Correa ["]	Código		B ["]		G ["]	A ["]	C ["]	F ["]	H ["]	
	Ø Rodillo ["]		Ø Rodillo ["]						Ø Rodillo ["]	
	5	6	5	6					5	6
36	C5461-36W	C6461-36W	39 7/16	39 1/4	19 17/27	53 3/4	51	16 5/16	7 1/2	7
42	C5461-42W	C6461-42W	45 3/8	45 3/16	22 17/27	59 3/4	57	16 13/16	8	7 1/2
48	C5461-48W	C6461-48W	51 1/4	51 1/16	25 17/27	65 3/4	63	17 5/16	8 1/2	8
54	C5461-54W	C6461-54W	57 1/8	56 15/16	28 17/27	71 3/4	69	17 13/16	9	8 1/2
60	C5461-60W	C6461-60W	63 1/16	62 7/8	31 17/27	77 3/4	75	18 5/16	9 1/2	9

Estación de Retorno en V Invertida

Serie CEMA C
 Servicio Mediano

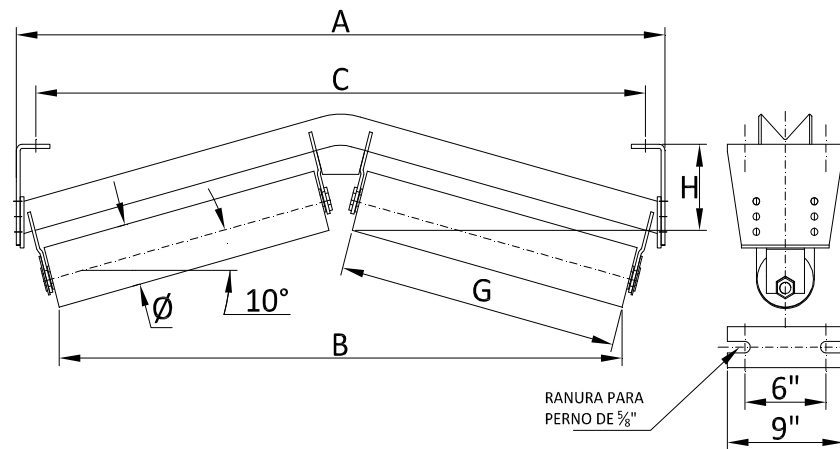

Base Estándar

Ancho Correa ["]	Código		B ["]		G ["]	A ["]	C ["]	H ["]	
	Ø Rodillo ["]		Ø Rodillo ["]					Ø Rodillo ["]	
	5	6	5	6				5	6
36	C5471-36	C6471-36	39 7/16	39 1/4	19 5/8	47 3/4	45	7	6 1/2
42	C5471-42	C6471-42	45 3/8	45 3/16	22 5/8	53 3/4	51	7 1/2	7
48	C5471-48	C6471-48	51 1/4	51 1/16	25 5/8	59 3/4	57	8	7 1/2
54	C5471-54	C6471-54	57 1/8	56 15/16	29 5/16	65 3/4	63	8 1/2	8
60	C5471-60	C6471-60	63 1/16	62 7/8	31 5/8	71 3/4	69	9	8 1/2

Base Ancha

Ancho Correa ["]	Código		B ["]		G ["]	A ["]	C ["]	H ["]	
	Ø Rodillo ["]		Ø Rodillo ["]					Ø Rodillo ["]	
	5	6	5	6				5	6
36	C5471-36W	C6471-36W	39 7/16	39 1/4	19 5/8	53 3/4	51	7 1/2	7
42	C5471-42W	C6471-42W	45 3/8	45 3/16	22 5/8	59 3/4	57	8	7 1/2
48	C5471-48W	C6471-48W	51 1/4	51 1/16	25 5/8	65 3/4	63	8 1/2	8
54	C5471-54W	C6471-54W	57 1/8	56 15/16	29 5/16	71 3/4	69	9	8 1/2
60	C5471-60W	C6471-60W	63 1/16	62 7/8	31 5/8	77 3/4	75	9 1/2	9

Estación de Retorno en V Invertida con Discos de Goma

Serie CEMA C
 Servicio Mediano

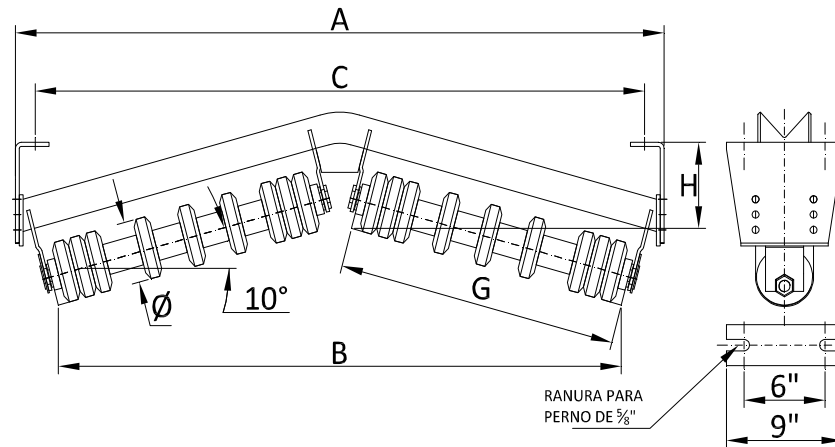

Base Estándar

Ancho Correa ["]	Código		B ["]		G ["]	A ["]	C ["]	H ["]	
	Ø Rodillo ["]		Ø Rodillo ["]					Ø Rodillo ["]	
	5	6	5	6				5	6
36	C5481-36	C6481-36	39 7/16	39 1/4	19 5/8	47 3/4	45	7	6 1/2
42	C5481-42	C6481-42	45 3/8	45 3/16	22 5/8	53 3/4	51	7 1/2	7
48	C5481-48	C6481-48	51 1/4	51 1/16	25 5/8	59 3/4	57	8	7 1/2
54	C5481-54	C6481-54	57 1/8	56 15/16	29 5/16	65 3/4	63	8 1/2	8
60	C5481-60	C6481-60	63 1/16	62 7/8	31 5/8	71 3/4	69	9	8 1/2

Base Ancha

Ancho Correa ["]	Código		B ["]		G ["]	A ["]	C ["]	H ["]	
	Ø Rodillo ["]		Ø Rodillo ["]					Ø Rodillo ["]	
	5	6	5	6				5	6
36	C5481-36W	C6481-36W	39 7/16	39 1/4	19 5/8	53 3/4	51	7 1/2	7
42	C5481-42W	C6481-42W	45 3/8	45 3/16	22 5/8	59 3/4	57	8	7 1/2
48	C5481-48W	C6481-48W	51 1/4	51 1/16	25 5/8	65 3/4	63	8 1/2	8
54	C5481-54W	C6481-54W	57 1/8	56 15/16	29 5/16	71 3/4	69	9	8 1/2
60	C5481-60W	C6481-60W	63 1/16	62 7/8	31 5/8	77 3/4	75	9 1/2	9

Estación Centradora de Carga

Serie CEMA C
 Servicio Mediano

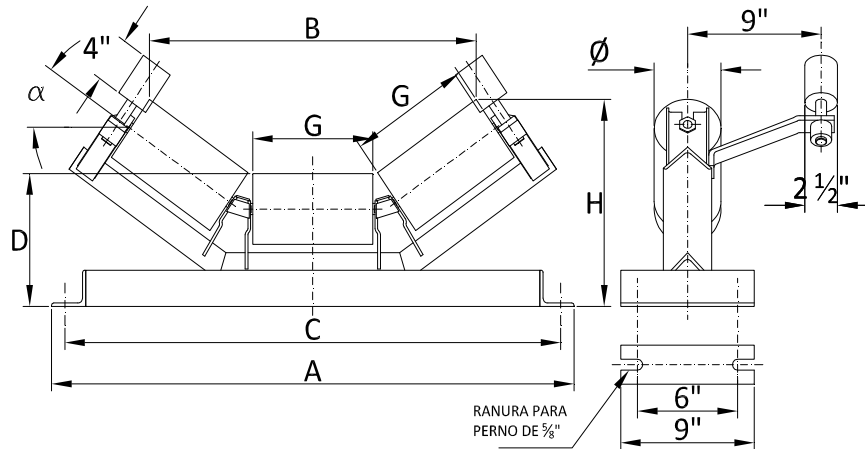

Ancho Correa ["]	Código		Ángulo Artesa [°]	A ["]	B ["]		C ["]	D ["]		G ["]	H ["]	
	Ø Rodillo ["]				Ø Rodillo ["]			Ø Rodillo ["]			Ø Rodillo ["]	
	5	6			5	6		5	6		5	6
18	C5602-18	C6602-18	20	29 1/2	21 1/2	21 1/8	27	9 1/2	10	6 7/8	12	12 1/2
	C5603-18	C6603-18	35		19 1/4	18 11/16					13 11/16	14 1/8
	C5604-18	C6604-18	45		17 13/16	17 1/16					14 5/8	14 15/16
20	C5602-20	C6602-20	20	31 1/2	23 5/16	23	29	9 1/2	10	7 9/16	12 1/4	12 3/4
	C5603-20	C6603-20	35		21	20 7/16					14 1/8	14 1/2
	C5604-20	C6604-20	45		19 7/16	18 3/4					15 1/16	15 7/16
24	C5602-24	C6602-24	20	35 1/2	27 1/4	26 7/8	33	9 1/2	10	8 7/8	12 11/16	13 3/16
	C5603-24	C6603-24	35		24 1/2	23 15/16					14 13/16	15 1/4
	C5604-24	C6604-24	45		22 5/8	21 15/16					16 1/16	16 3/8
30	C5602-30	C6602-30	20	41 1/2	33	32 5/8	39	9 1/2	10	10 7/8	13 3/8	13 7/8
	C5603-30	C6603-30	35		29 13/16	29 1/4					15	16 3/8
	C5604-30	C6604-30	45		27 1/2	26 3/4					17 7/16	17 13/16
36	C5602-36	C6602-36	20	47 1/2	38 3/4	38 3/8	45	9 1/2	10	12 7/8	14 1/16	14 9/16
	C5603-36	C6603-36	35		35 1/16	34 1/2					17 1/8	17 1/2
	C5604-36	C6604-36	45		32 5/16	31 5/8					18 7/8	19 1/4
42	C5602-42	C6602-42	20	53 1/2	44 1/2	44 1/8	51	10	10 1/2	14 7/8	15 1/4	15 3/4
	C5603-42	C6603-42	35		40 3/8	39 13/16					18 3/4	19 3/16
	C5604-42	C6604-42	45		37 3/16	36 13/16					20 13/16	21 1/8
48	C5602-48	C6602-48	20	59 1/2	50 1/4	49 7/8	57	10	10 1/2	16 7/8	15 15/16	16 7/16
	C5603-48	C6603-48	35		45 5/8	45 1/16					19 7/8	20 5/16
	C5604-48	C6604-48	45		42	41 5/16					22 1/4	22 9/16
54	C5602-54	C6602-54	20	65 1/2	56	55 5/8	63	10 1/4	10 3/4	18 7/8	16 7/8	17 3/8
	C5603-54	C6603-54	35		50 15/16	50 3/8					21 5/16	21 11/16
	C5604-54	C6604-54	45		46 7/8	46 1/8					23 7/8	24 1/4
60	C5602-60	C6602-60	20	71 1/2	61 3/4	61 3/8	69	10 1/4	10 3/4	20 7/8	16 9/16	18 1/16
	C5603-60	C6603-60	35		56 3/16	55 5/8					22 7/16	22 13/16
	C5604-60	C6604-60	45		51 11/16	50					25 5/16	25 11/16

Estaciones de base ancha: sumar 6" a cotas A y C. Agregar W a código según nomenclatura
 Medidas pueden ser modificadas para adaptarse a requerimientos del Cliente
 Diseño sujeto a cambio sin previo aviso.

Estación Centradora de Retorno Plana

Serie CEMA C
 Servicio Mediano

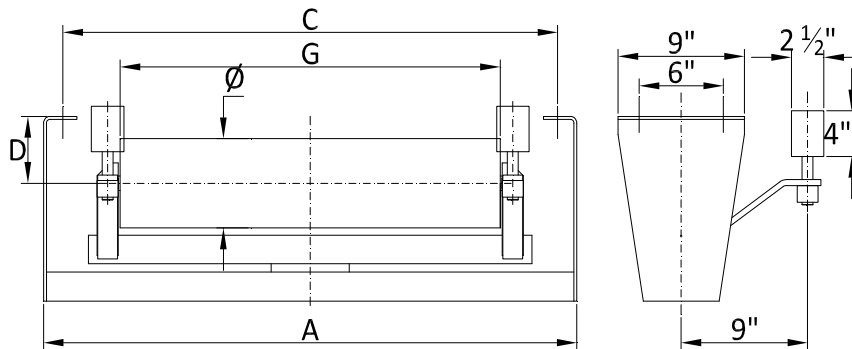

D = DROP ESTANDAR 1 1/2"
 D = DROP ALTO 4 1/2"

Ancho Correa ["]	Código		A ["]	C ["]	G ["]
	Ø Rodillo ["]				
	5	6			
18	C5620-18	C6620-18	29 3/4	27	21
20	C5620-20	C6620-20	31 3/4	29	23
24	C5620-24	C6620-24	35 3/4	33	27
30	C5620-30	C6620-30	41 3/4	39	33
36	C5620-36	C6620-36	47 3/4	45	39
42	C5620-42	C6620-42	53 3/4	51	45
48	C5620-48	C6620-48	59 3/4	57	51
54	C5620-54	C6620-54	65 3/4	63	57
60	C5620-60	C6620-60	71 3/4	69	63

Estaciones de base ancha: sumar 6" a cotas A y C. Agregar W a código según nomenclatura
 Medidas pueden ser modificadas para adaptarse a requerimientos del Cliente
 Diseño sujeto a cambio sin previo aviso.

Estación Centradora de Retorno con Discos de Goma

Serie CEMA C
 Servicio Mediano

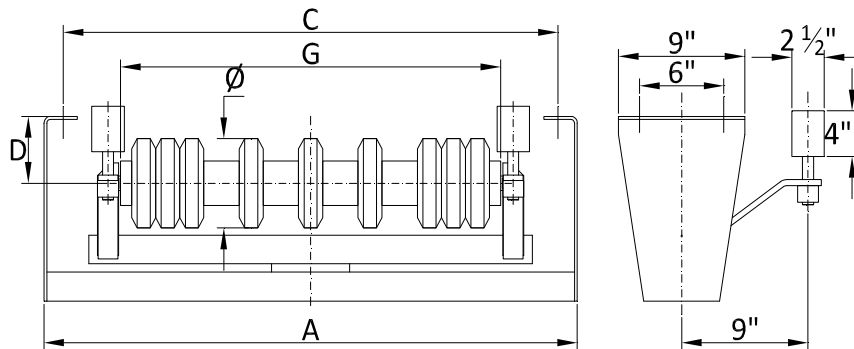

D = DROP ESTANDAR 1 1/2"
 D = DROP ALTO 4 1/2"

Ancho Correa [\"]	Código		A [\"]	C [\"]	G [\"]
	Ø Rodillo [\"]				
	5	6			
18	C5640-18	C6640-18	29 3/4	27	21
20	C5640-20	C6640-20	31 3/4	29	23
24	C5640-24	C6640-24	35 3/4	33	27
30	C5640-30	C6640-30	41 3/4	39	33
36	C5640-36	C6640-36	47 3/4	45	39
42	C5640-42	C6640-42	53 3/4	51	45
48	C5640-48	C6640-48	59 3/4	57	51
54	C5640-54	C6640-54	65 3/4	63	57
60	C5640-60	C6640-60	71 3/4	69	63

Estaciones de base ancha: sumar 6\" a cotas A y C. Agregar W a código según nomenclatura
 Medidas pueden ser modificadas para adaptarse a requerimientos del Cliente
 Diseño sujeto a cambio sin previo aviso.

Estación Centradora de Retorno Helicoidal

Serie CEMA C
 Servicio Mediano

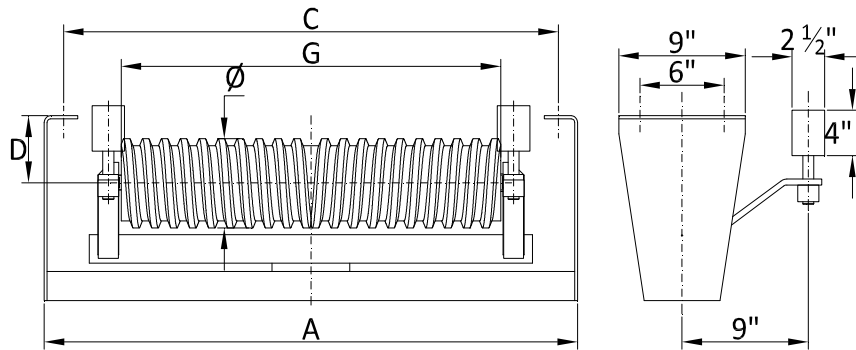

D = DROP ESTANDAR 1 1/2"
 D = DROP ALTO 4 1/2"

Ancho Correa ["]	Código		A ["]	C ["]	G ["]
	Ø Rodillo ["]				
	5	6			
18	C5660-18	C6660-18	29 3/4	27	21
20	C5660-20	C6660-20	31 3/4	29	23
24	C5660-24	C6660-24	35 3/4	33	27
30	C5660-30	C6660-30	41 3/4	39	33
36	C5660-36	C6660-36	47 3/4	45	39
42	C5660-42	C6660-42	53 3/4	51	45
48	C5660-48	C6660-48	59 3/4	57	51
54	C5660-54	C6660-54	65 3/4	63	57
60	C5660-60	C6660-60	71 3/4	69	63

Estaciones de base ancha: sumar 6" a cotas A y C. Agregar W a código según nomenclatura
 Medidas pueden ser modificadas para adaptarse a requerimientos del Cliente
 Diseño sujeto a cambio sin previo aviso.

Estación Alimentadora de Carga

Serie CEMA C
 Servicio Mediano

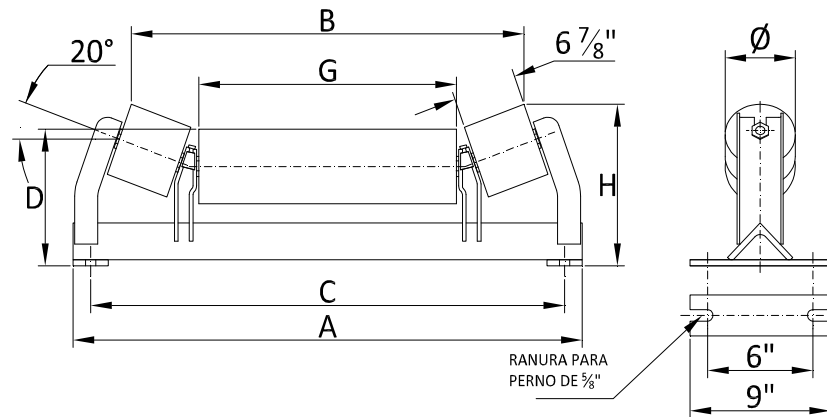

Ancho Correa ["]	Código		A ["]	B ["]		C ["]	D ["]		G ["]	H ["]	
	Ø Rodillo ["]			Ø Rodillo ["]			Ø Rodillo ["]			Ø Rodillo ["]	
	5	6		5	6		5	6		5	6
24	C5802-24	C6802-24	35 1/2	27 7/16	27 1/16	33	8 1/2	9	12 7/8	11 1/16	11 9/16
30	C5802-30	C6802-30	41 1/2	33 7/16	33	39	8 1/2	9	18 7/8	11 1/16	11 9/16
36	C5802-36	C6802-36	47 1/2	39 7/16	39	45	8 1/2	9	24 7/8	11 1/16	11 9/16
42	C5802-42	C6802-42	53 1/2	45 7/16	45	51	9	9 1/2	30 7/8	11 9/16	12 1/16
48	C5802-48	C6802-48	59 1/2	51 7/16	51 1/16	57	9	9 1/2	36 7/8	11 9/16	12 1/16
54	C5802-54	C6802-54	65 1/2	57 7/16	57	63	9 1/4	9 3/4	42 7/8	11 13/16	12 5/16
60	C5802-60	C6802-60	71 1/2	63 7/16	63	69	9 1/4	9 3/4	48 7/8	11 13/16	12 5/16

Estaciones de base ancha: sumar 6" a cotas A y C. Agregar W a código según nomenclatura
 Medidas pueden ser modificadas para adaptarse a requerimientos del Cliente
 Diseño sujeto a cambio sin previo aviso.

Estación Alimentadora de Impacto

Serie CEMA C
 Servicio Mediano

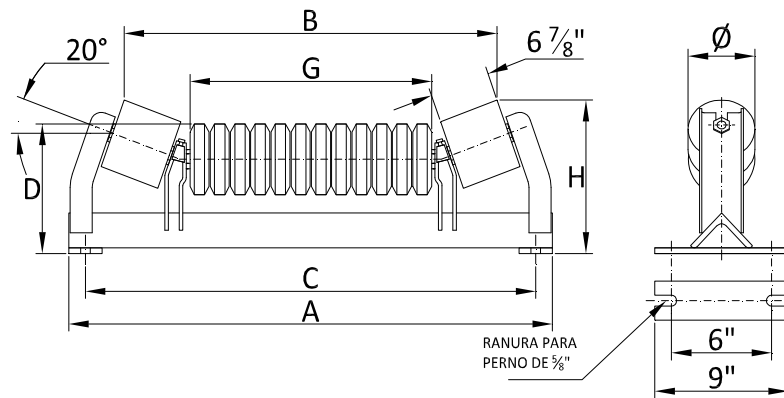

Ancho Correa ["]	Código		A ["]	B ["]		C ["]	D ["]		G ["]	H ["]	
	Ø Rodillo ["]			Ø Rodillo ["]			Ø Rodillo ["]			Ø Rodillo ["]	
	5	6		5	6		5	6		5	6
24	C5812-24	C6812-24	35 1/2	27 7/16	27 1/16	33	8 1/2	9	12 7/8	11 1/16	11 9/16
30	C5812-30	C6812-30	41 1/2	33 7/16	33	39	8 1/2	9	18 7/8	11 1/16	11 9/16
36	C5812-36	C6812-36	47 1/2	39 7/16	39	45	8 1/2	9	24 7/8	11 1/16	11 9/16
42	C5812-42	C6812-42	53 1/2	45 7/16	45	51	9	9 1/2	30 7/8	11 9/16	12 1/16
48	C5812-48	C6812-48	59 1/2	51 7/16	51 1/16	57	9	9 1/2	36 7/8	11 9/16	12 1/16
54	C5812-54	C6812-54	65 1/2	57 7/16	57	63	9 1/4	9 3/4	42 7/8	11 13/16	12 5/16
60	C5812-60	C6812-60	71 1/2	63 7/16	63	69	9 1/4	9 3/4	48 7/8	11 13/16	12 5/16

Estaciones de base ancha: sumar 6" a cotas A y C. Agregar W a código según nomenclatura
 Medidas pueden ser modificadas para adaptarse a requerimientos del Cliente
 Diseño sujeto a cambio sin previo aviso.

Estación de Ángulo Variable

Serie CEMA C
 Servicio Mediano

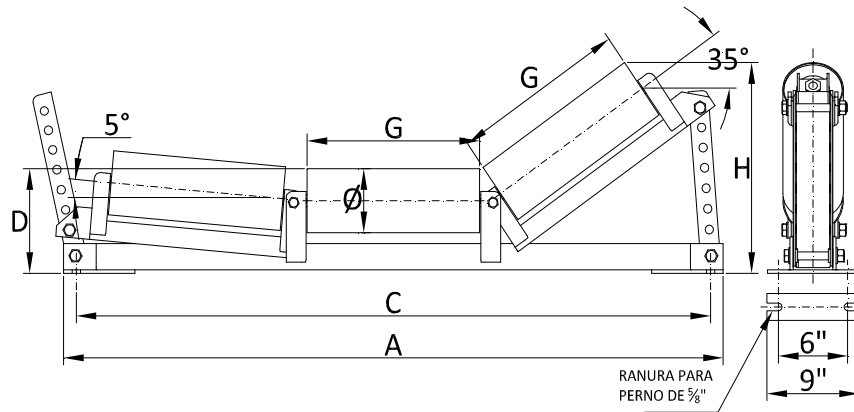

Ancho Correa ["]	Código		A ["]	C ["]	D ["]		G ["]	H ["]	
	Ø Rodillo ["]				Ø Rodillo ["]			Ø Rodillo ["]	
	5	6			5	6		5	6
24	C5822-24	C6822-24	38	33	9 1/4	9 3/4	8 7/8	12	12 1/2
30	C5822-30	C6822-30	44	39	9 1/4	9 3/4	10 7/8	12 7/8	13 3/8
36	C5822-36	C6822-36	50	45	9 1/4	9 3/4	12 7/8	13 5/8	14 1/8
42	C5822-42	C6822-42	56	51	9 3/4	10 1/4	14 7/8	14 1/4	14 3/4
48	C5822-48	C6822-48	62	57	9 3/4	10 1/4	16 7/8	15 1/2	16
54	C5822-54	C6822-54	68	63	10	10 1/2	18 7/8	16 1/4	16 3/4
60	C5822-60	C6822-60	74	69	10	10 1/2	20 7/8	16 7/8	17 3/8

Estaciones de base ancha: sumar 6" a cotas A y C. Agregar W a código según nomenclatura
 Medidas pueden ser modificadas para adaptarse a requerimientos del Cliente
 Diseño sujeto a cambio sin previo aviso.

Estación Live Shaft

Serie CEMA C
 Servicio Mediano

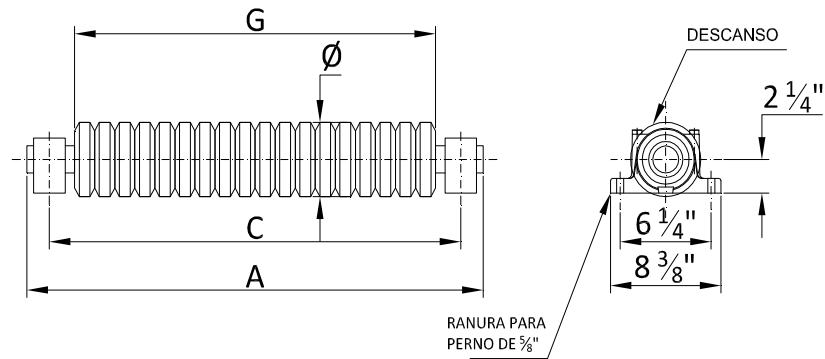

Ancho Correa [\""]	Código		A [\""]	C [\""]	G [\""]
	Ø Rodillo [\""]				
	5	6			
18	C5830-18	C6830-18	31	27	20 7/8
20	C5830-20	C6830-20	33	29	22 7/8
24	C5830-24	C6830-24	37	33	26 7/8
30	C5830-30	C6830-30	43	39	32 7/8
36	C5830-36	C6830-36	49	45	38 7/8
42	C5830-42	C6830-42	55	51	44 7/8
48	C5830-48	C6830-48	61	57	50 7/8
54	C5830-54	C6830-54	67	63	56 7/8
60	C5830-60	C6830-60	73	69	62 7/8

Estaciones de base ancha: sumar 6\" a cotas A y C. Agregar W a código según nomenclatura
 Medidas pueden ser modificadas para adaptarse a requerimientos del Cliente
 Diseño sujeto a cambio sin previo aviso.

Estación Pesométrica

Serie CEMA C
 Servicio Mediano

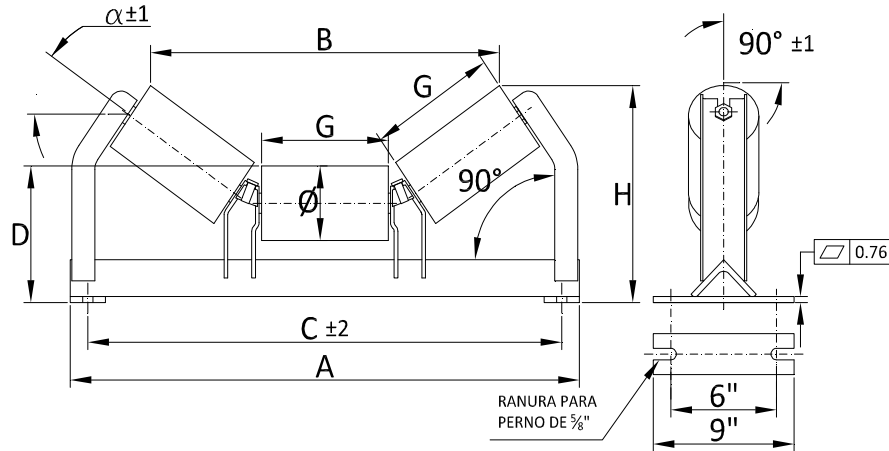

Ancho Correa [""]	Código		Ángulo Artesa [°]	A [""]	B [""]		C [""]	D [""]		G [""]	H [""]	
	Ø Rodillo [""]				Ø Rodillo [""]			Ø Rodillo [""]			Ø Rodillo [""]	
	5	6			5	6		5	6		5	6
18	C5842-18	C6842-18	20	29 1/2	21 1/2	21 1/8	27	8 1/2	9	6 7/8	11	11 1/2
	C5843-18	C6843-18	35		19 1/4	18 11/16					12 11/16	13 1/8
	C5844-18	C6844-18	45		17 13/16	17 1/16					13 5/8	13 15/16
20	C5842-20	C6842-20	20	31 1/2	23 5/16	23	29	8 1/2	9	7 9/16	11 1/4	11 3/4
	C5843-20	C6843-20	35		21	20 7/16					13 1/8	13 1/2
	C5844-20	C6844-20	45		19 7/16	18 3/4					14 1/16	14 7/16
24	C5842-24	C6842-24	20	35 1/2	27 1/4	26 7/8	33	8 1/2	9	8 7/8	11 11/16	12 3/16
	C5843-24	C6843-24	35		24 1/2	23 15/16					13 13/16	14 1/4
	C5844-24	C6844-24	45		22 5/8	21 15/16					15 1/16	15 3/8
30	C5842-30	C6842-30	20	41 1/2	33	32 5/8	39	8 1/2	9	10 7/8	12 3/8	12 7/8
	C5843-30	C6843-30	35		29 13/16	29 1/4					14	15 3/8
	C5844-30	C6844-30	45		27 1/2	26 3/4					16 7/16	16 13/16
36	C5842-36	C6842-36	20	47 1/2	38 3/4	38 3/8	45	8 1/2	9	12 7/8	13 1/16	13 9/16
	C5843-36	C6843-36	35		35 1/16	34 1/2					16 1/8	16 1/2
	C5844-36	C6844-36	45		32 5/16	31 5/8					17 7/8	18 1/4
42	C5842-42	C6842-42	20	53 1/2	44 1/2	44 1/8	51	9	9 1/2	14 7/8	14 1/4	14 3/4
	C5843-42	C6843-42	35		40 3/8	39 13/16					17 3/4	18 3/16
	C5844-42	C6844-42	45		37 3/16	36 13/16					19 13/16	20 1/8
48	C5842-48	C6842-48	20	59 1/2	50 1/4	49 7/8	57	9	9 1/2	16 7/8	14 15/16	15 7/16
	C5843-48	C6843-48	35		45 5/8	45 1/16					18 7/8	19 5/16
	C5844-48	C6844-48	45		42	41 5/16					21 1/4	21 9/16
54	C5842-54	C6842-54	20	65 1/2	56	55 5/8	63	9 1/4	9 3/4	18 7/8	15 7/8	16 3/8
	C5843-54	C6843-54	35		50 15/16	50 3/8					20 5/16	20 11/16
	C5844-54	C6844-54	45		46 7/8	46 1/8					22 7/8	23 1/4
60	C5842-60	C6842-60	20	71 1/2	61 3/4	61 3/8	69	9 1/4	9 3/4	20 7/8	16 9/16	17 1/16
	C5843-60	C6843-60	35		56 3/16	55 5/8					21 7/16	21 13/16
	C5844-60	C6844-60	45		51 11/16	50					24 5/16	24 11/16

Nota: a solicitud del Cliente se ofrece balanceo dinámico y fabricación con otras tolerancias

Estaciones de base ancha: sumar 6" a cotas A y C. Agregar W a código según nomenclatura

Medidas pueden ser modificadas para adaptarse a requerimientos del Cliente. Diseño sujeto a cambio sin previo aviso